

APPENDIX B

Pierre Boulez: Dialogue de l'ombre double (1985)

an imagined effect of spatialization

analysis by Matt Malsky

1. single speakers as sources

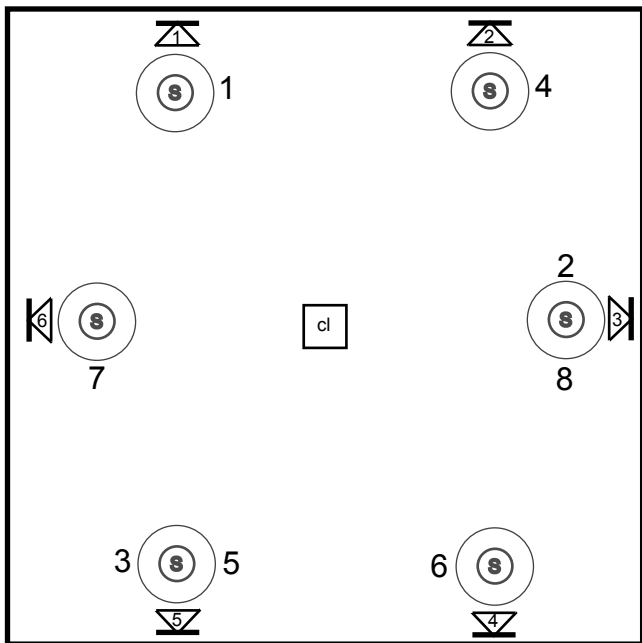

2. "stereophonic" pair as source

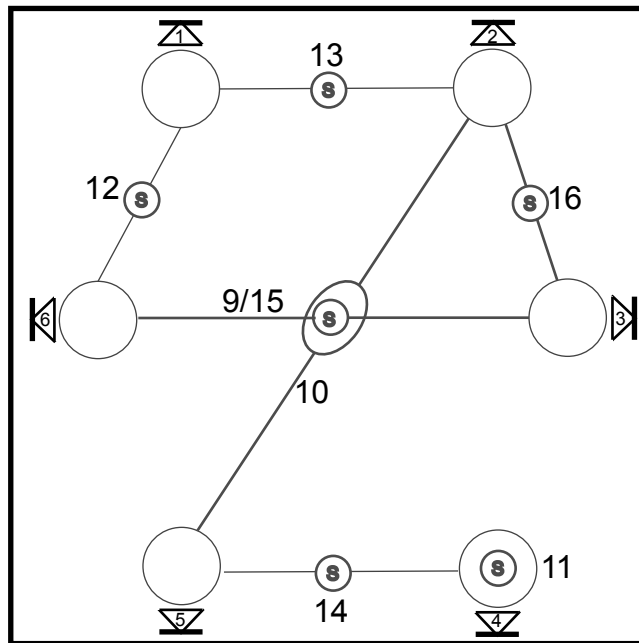

3. speaker "triplets" as source

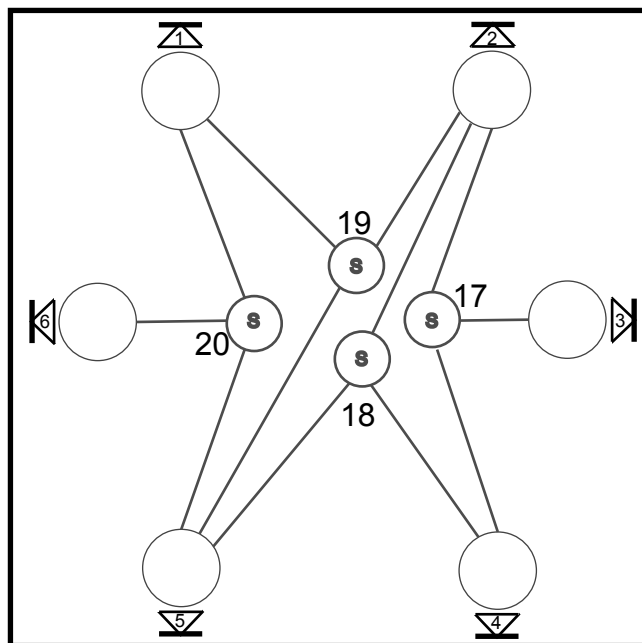

4. progressive spatial enlargement

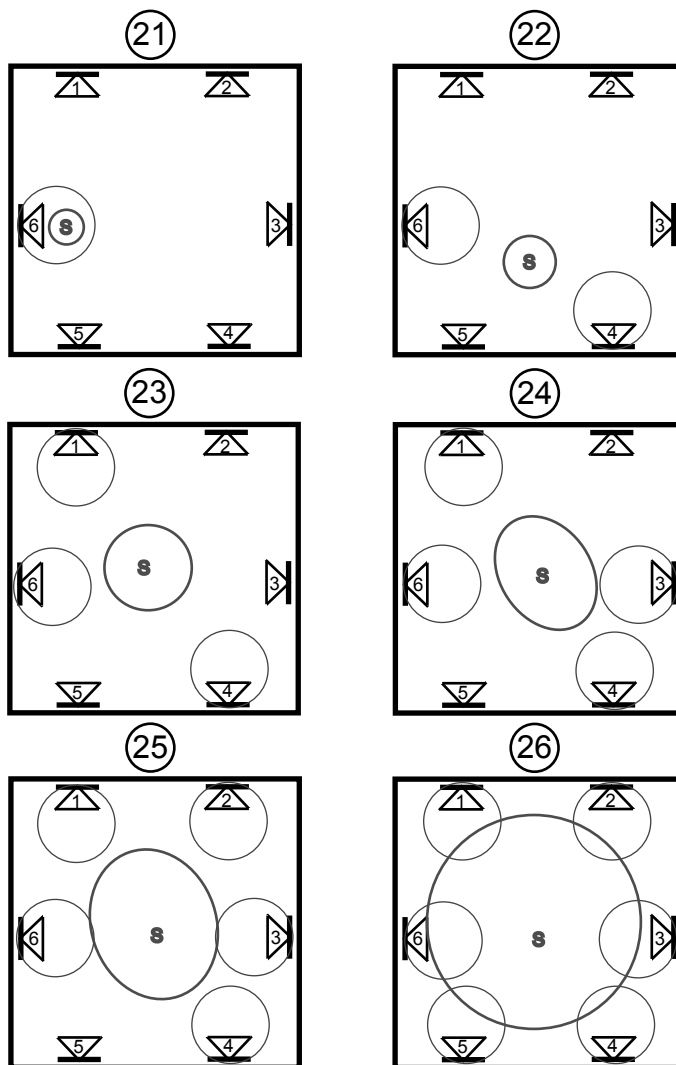

KEY:

loudspeaker

apparent sound source

1- phrase/cue number from score